

VARIABLE-FREQUENCY PUMP SYSTEM

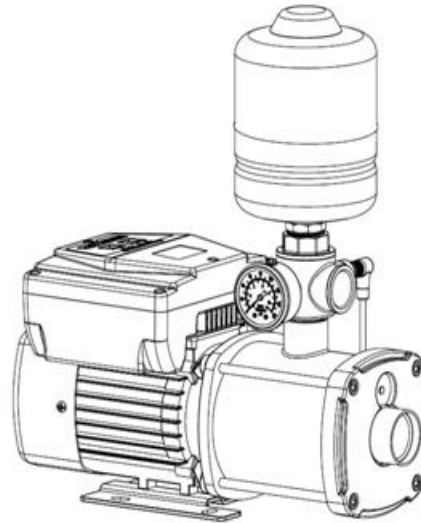

Read this manual carefully before installation. The product can Not be used for medical industry has the potential to cause personal injury, also can't be used for pumping other liquids than water.

CONTENT

1. Summary	
1.1 Product Introduction.....	4
1.2 Application Range	4
1.3 Product Advantage.....	4
1.4 Operating Conditions	4
2. Safety and Notice	
2.1 Notice For Use	5
2.2 Application Area.....	6
2.3 Notice For Environmental Conditions.....	6
3. Product Appearance Dimensions And Technical Parameters	
3.1 Product Appearance Dimensions.....	7
3.2 Product Dimension Table.....	8
3.3 Technical Data.....	9
3.4 Pump Performance Curve.....	12
3.4.1 VFI2 Performance Curve.....	12
3.4.2 VFI4 Performance Curve.....	13
3.4.3 VFI8 Performance Curve.....	14
3.4.4 VFI8B Performance Curve.....	15
3.4.5 VFI12 Performance Curve	16
3.4.7 VFI12B Performance Curve.....	17
3.4.8 VFI16 Performance Curve	18
3.4.9 VFI20 Performance Curve.....	19
4. Installation and Operation instruction	
4.1 Structure Diagram And Installation Instructions.....	20
4.2 Wiring Diagram and Instruction.....	21
4.3 Operation Instruction	22
4.3.1 Checking before Operation	22
4.3.2 Operating Steps.....	22
4.3.3 Button and Function Instruction	24
4.3.4 Code and Instruction	25
5. Maintenance	
5.1 Notices for Product Maintenance.....	26

1. Summary

1.1 Product Introduction

VF series Variable-frequency pump adopts the latest VVVF(Variable Voltage and Variable Frequency),AC Frequency conversion speed regulation technology combined with pressure sensor technology,through the feedback of real-time pressure value compared with the setting pressure, it can automatically adjust the motor speed,and keep the outlet pressure constant.

1.2 Application Range

It can apply to life,production water supply for various types of high-rise buildings , such as water plants. restaurants, hotels, residential areas etc.

1.3 Product Advantage

1.Energy-efficient .Compared with the traditional way of water supply, the Variable-frequency pump system can save energy of 30% to 60%.

2.Small occupied area, less investment and high efficiency.

3.Flexible configuration, high degree of automation, complete functions, flexible and reliable.

4.Operation performance is reasonable, the average torque and abrasion on the shaft is reduced because of the decline for average speed in one day, the life of pump will improved .

5.Because it can realize the soft stop and soft start of water pump, it can eliminate water effect . (water hammer effect means:direct starting and stopping ,liquid kinetic energy of a hammer sharp change, lead to the great impact of the network,there iage .)

1.Summary

6.Easy installation, it replaces water tower ,high water tank and traditional air pressure tank water supply device.

7.Direct pressurized water supply reduces the secondary pollution of water quality caused by traditional pressure tank water supply device.

8.The spare parts which flowed by water is all stainless (304 or 316), guarantee the healthy of using water .

1.4 Operating Conditions

1.Liquid:non frozen water.

2.Liquid temperature:0~+104℃.

2.Safety and Notice

2.1 Notice

1.Please read the manual carefully before installation and using.

2.Pay more attention to the safety warnings and instructions in the manual.

 The risk of general electric:If violate , the pump will broken and people will get hurt .

 The danger caused by electrical appliances ,If violate , the pump will broken and people will get hurt

3.If anyone who will not abide the safety warnings and instructions in the manual so that cause injuries and any other property damage , our company will not assume any form of liability or joint and several liability, also don't pay any compensation.several liability, also don't pay any compensation .

4.Safety warnings content:

 DANGER	1.Please be sure to use the correct power supply to ensure that power conform to the requirements of the product.
	2.Please cut off the power supply before installation and maintenance; ensure the reliable grounding measures. If Not, can't use.
	3.If don't use the pump for a long time, please closed the inlet pipe valve and cut off the power .
	4.Don't install the water pump in any wet place or the place may water splashed.
	5.If the storing time is more than 2 years, boosting the pressure through the voltage regulator gradually when power on, otherwise there is risk of electric shock and explosion.
	6.Don't touch the controller terminals when the power on ,otherwise there is risk of electric shock.
	7.Maintenance needs to be 5 minutes later after cutting off the power,at that time all the indicator light should be went out completely,otherwise there is risk of electric shock.
	8.Don't use wet hand operate the control panel, otherwise there is risk of electric shock.
	9.If the wire aging or damaged , it must be replaced by professionals.

2.Safety and notice



- | |
|--|
| 1.Installation and the operator must comply with local safety regulations. |
| 2.Installation and maintenance only can be operated by professionals. |
| 3.The user must confirm: installation and maintenance must be operated by professionals who proficient in this manual. |
| 4.If the motor heating or abNormal , please close the inlet valve immediately and cut off the power, contact the dealers or service center.The pump can be continue to start until clearing the fault. |
| 5.If can Not eliminate the pump fault according with the manual, please close the inlet valve immediately and cut off the power , contact the dealers or service center .The pump can be continue to start until clearing the fault. |
| 6.This product should be placed where children can Not touch, isolation measures should be taken after the installation is complete, in order to prevent the children touch. |
| 7.The product should be placed in dry and ventilated, shady and cool place, kept at room temperature. |
| 8. In summer or the high temperature environment, it should be paid attention to ventilation, avoid causing condenser water and dew, which lead to electrical equipment error. |

2.2 Product Checking

Every products should finish the testing of all functional items before leaving factory,clients need to take the following test after receiving the products :

- 1.Make sure the Model and type is what you have ordered .
- 2.Check whether the products is damaged caused by transportation,if it has,don't access the power.

2.Safety and notice

2.3 Notice For Environmental Conditions

The installation condition of the inverter constant pressure water supply system have a direct impact on the function and service life,so the installation condition must conform to the following:

- Products can be used in indoor environment
- Environment temperature:-10°C ~+40°C
- The installation environment can't be damp but good ventilation
- Stay away from the radioactive substance and fuel
- Avoid electro-magnetic interference

3.Product Appearance Dimensions And Technical Parameters

3.1 Product Appearance Dimensions

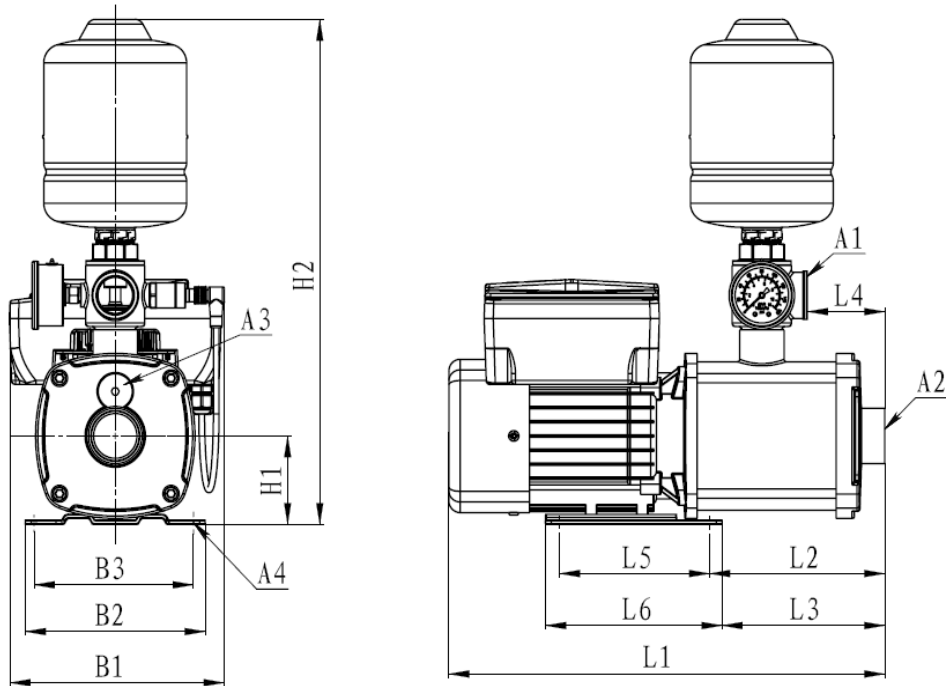

3.Product Appearance Dimensions And Technical Parameters

3.2 VFI Appearance Dimensions Table

AC 220V/50Hz series																
No	Model	Dimensions(mm)														
		A1	A2	A3	A4	B1	B2	B3	H1	H2	L1	L2	L3	L4	L5	L6
1	VFI2-2	G1	G1	G3/8	11	189	158	125	75	428	318	131	113	32	96	136
2	VFI2-3	G1	G1	G3/8	11	189	158	125	75	428	318	131	113	32	96	136
3	VFI2-4	G1	G1	G3/8	11	189	158	125	75	428	336	149	131	50	96	136
4	VFI2-5	G1	G1	G3/8	11	189	158	125	75	428	383	167	143	68	96	136
5	VFI2-6	G1	G1	G3/8	11	189	158	125	75	428	416	203	179	104	96	155
6	VFI4-2	G1	G1¼	G3/8	11	189	158	125	75	428	318	131	113	32	96	136
7	VFI4-3	G1	G1¼	G3/8	11	189	158	125	75	428	318	131	113	32	96	136
8	VFI4-4	G1	G1¼	G3/8	11	189	158	125	75	428	362	149	125	50	96	155
9	VFI4-5	G1	G1¼	G3/8	11	189	158	125	75	428	380	167	143	68	96	155
10	VFI4-6	G1	G1¼	G3/8	11	189	158	140	90	443	446	243	228	104	125	155
11	VFI8-15	G1½	G1½	G3/8	11	210	158	125	100	550	377	185	170	50	96	136
12	VFI8-20	G1½	G1½	G3/8	11	210	158	125	100	550	377	185	170	50	96	136
13	VFI8-25	G1½	G1½	G3/8	11	210	158	125	100	550	408	200	185	50	96	136
14	VFI8-30	G1½	G1½	G3/8	11	210	158	125	100	550	408	200	185	50	96	136
15	VFI8-35	G1½	G1½	G3/8	11	210	158	125	100	550	438	230	215	80	96	136
16	VFI8-40	G1½	G1½	G3/8	11	210	158	125	100	550	438	230	215	80	96	136
17	VFI8-20B	G1½	G1½	G3/8	11	210	158	125	100	550	377	185	170	50	96	136
18	VFI8-30B	G1½	G1½	G3/8	11	210	158	125	100	550	408	200	185	50	96	136

3. Product Appearance Dimensions and Technical Data

AC 220V/50Hz series																
No	Model	Dimensions(mm)														
		A1	A2	A3	A4	B1	B2	B3	H1	H2	L1	L2	L3	L4	L5	L6
19	VFI8-40B	G1½	G1½	G3/8	11	210	158	125	100	550	438	230	215	80	96	136
20	VFI8-50B	G1½	G1½	G3/8	11	210	158	125	100	550	498	290	275	140	96	136
21	VFI12-10	G2	G2	G3/8	11	210	158	125	100	550	377	185	170	50	96	136
22	VFI12-15	G2	G2	G3/8	11	210	158	125	100	550	408	185	170	50	96	136
23	VFI12-20	G2	G2	G3/8	11	210	158	125	100	550	408	185	170	50	96	136
24	VFI12-25	G2	G2	G3/8	11	210	158	125	100	550	409	185	170	50	96	136
25	VFI12-30	G2	G2	G3/8	11	210	158	160	100	550	469	185	170	50	140	136
26	VFI12-10B	G2	G2	G3/8	11	210	158	125	100	550	377	185	170	50	96	136
27	VFI12-20B	G2	G2	G3/8	11	210	158	125	100	550	408	200	185	50	96	136
28	VFI12-30B	G2	G2	G3/8	11	210	158	125	100	550	408	200	185	50	96	136
29	VFI12-40B	G2	G2	G3/8	11	210	158	125	100	550	438	200	185	80	96	136
30	VFI12-50B	G2	G2	G3/8	11	210	158	160	100	550	539	290	275	140	140	136
31	VFI16-10	G2	G2	G3/8	11	210	158	125	100	568	408	215	200	72	96	136
32	VFI16-20	G2	G2	G3/8	11	210	158	125	100	568	439	230	215	72	96	136
33	VFI16-30	G2	G2	G3/8	11	210	158	160	100	568	580	230	215	72	140	136
34	VFI20-10	G2	G2	G3/8	11	210	158	125	100	568	408	215	200	72	96	136
35	VFI20-20	G2	G2	G3/8	11	210	158	125	100	568	439	230	215	72	96	136
36	VFI20-30	G2	G2	G3/8	11	210	158	160	100	568	500	230	215	72	140	136

3.Product Appearance Dimensions And Technical Parameters

3.3 VFI Series Technical Parameters Table

AC 220V/50Hz series								
No	Model	rated power	rated flow	rated head	factory setting	voltage regulating range	pressure tank size	tank inflation value
		(KW)	(m ³ /h)	(m)	(bar)	(bar)		(bar)
1	VFI2-2	0,25	2	18	1.5	1.0~1.8	2L	2.0
2	VFI2-3	0,37		24	2.0	1.0~2.4	2L	2.0
3	VFI2-4	0,55		32	2.0	1.0~3.2	2L	2.0
4	VFI2-5	0,55		40	2.0	1.0~4.0	2L	2.0
5	VFI2-6	0,75		47	2.0	1.0~4.7	2L	2.0
6	VFI4-2	0,37	4	15	1.5	1.0~1.5	2L	2.0
7	VFI4-3	0,55		25	2.0	1.0~2.5	2L	2.0
8	VFI4-4	0,75		30	2.0	1.0~3.0	2L	2.0
9	VFI4-5	1		40	2.0	1.0~4.0	2L	2.0
10	VFI4-6	1,3		49	2.0	1.0~4.9	2L	2.0
11	VFI8-15	0,75	8	20	2.0	1.0~2.0	4L	2.0
12	VFI8-20	1		24	2.0	1.0~2.4	4L	2.0
13	VFI8-25	1,5		27	2.0	1.0~2.7	4L	2.0
14	VFI8-30	1,85		36	2.0	1.0~3.6	4L	2.0
15	VFI8-35	2,2		43	2.0	1.0~4.3	4L	2.0
16	VFI8-40	2,2		48	2.0	1.0~4.8	4L	2.0
17	VFI8-20B	0,75		19	2.0	1.0~1.9	4L	2.0
18	VFI8-30B	1,1		26	2.0	1.0~2.6	4L	2.0

3.Product Appearance Dimensions And Technical Parameters

AC 220V/50Hz series								
No	Model	rated power	rated flow	rated head	factory setting	voltage regulating range	pressure tank size	tank inflation value
		(KW)	(m ³ /h)	(m)	(bar)	(bar)		(bar)
19	VFI8-40B	1,5	8	37	2.0	1.0~3.7	4L	2.0
20	VFI8-50B	2,2		46,5	2.0	1.0~4.7	4L	2.0
21	VFI12-10	1	12	13,5	1.5	1.0~1.4	4L	2.0
22	VFI12-15	1,5		20	2.0	1.0~2.0	4L	2.0
23	VFI12-20	1,85		28	2.0	1.0~2.8	4L	2.0
24	VFI12-25	2,2		33,5	2.0	1.0~3.4	4L	2.0
25	VFI12-30	3		39	2.0	1.0~3.9	4L	2.0
26	VFI12-10B	0,75		9,5	1.0	1.0~1.0	4L	2.0
27	VFI12-20B	1,1		19,5	2.0	1.0~2.0	4L	2.0
28	VFI12-30B	1,85		29,5	2.0	1.0~3.0	4L	2.0
29	VFI12-40B	2,2		39,5	2.0	1.0~4.0	4L	2.0
30	VFI12-50B	3		50	2.0	1.0~5.0	4L	2.0
31	VFI16-10	1	16	10	1.0	1.0~1.0	4L	2.0
32	VFI16-20	1,5		20	2.0	1.0~2.0	4L	2.0
33	VFI16-30	2,2		30	2.0	1.0~3.0	4L	2.0
34	VFI20-10	1	20	10,5	1.1	1.0~1.1	4L	2.0
35	VFI20-20	1,85		20	2.0	1.0~2.0	4L	2.0
36	VFI20-30	3		31,5	2.0	1.0~3.2	4L	2.0

Attention:Change the value of pressure filled in tank when user want to chang the pressure,the value is 60percent of the setting pressure value.

3.Product Appearance Dimensions And Technical Parameters

3.4 pump Performance Curve

3.4.1 VF12 Performance Curve

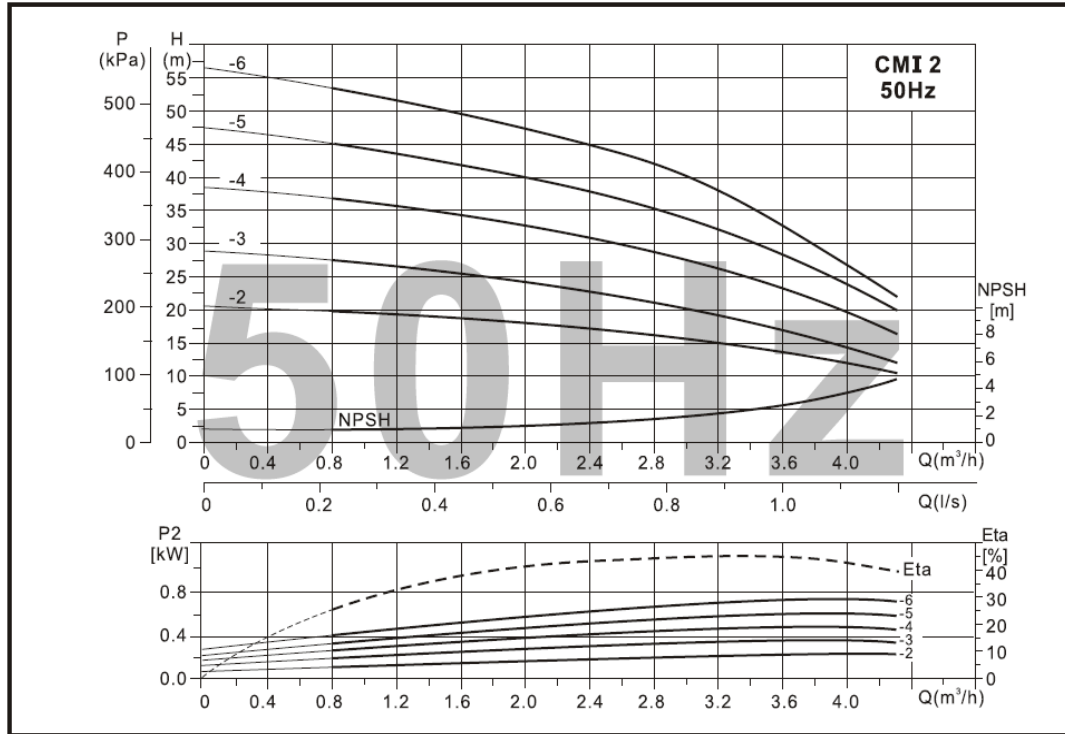

3.Product Appearance Dimensions And Technical Parameters

3.4.2 VFI4 Performance Curve

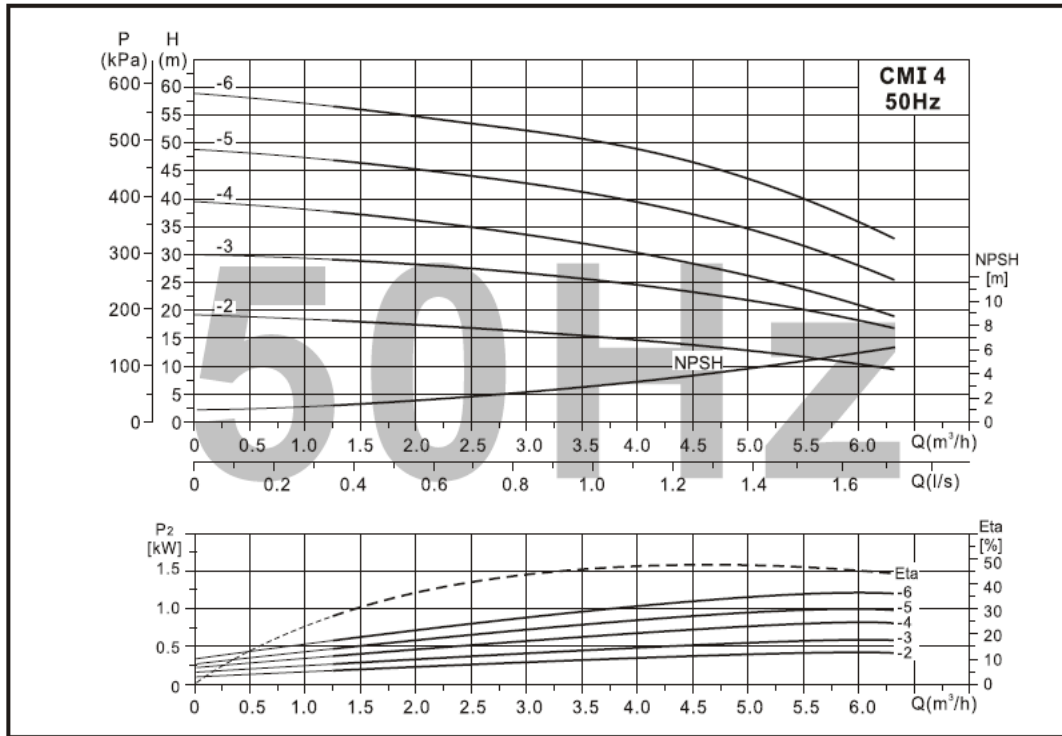

3.Product Appearance Dimensions And Technical Parameters

3.4.3 VF18 Performance Curve

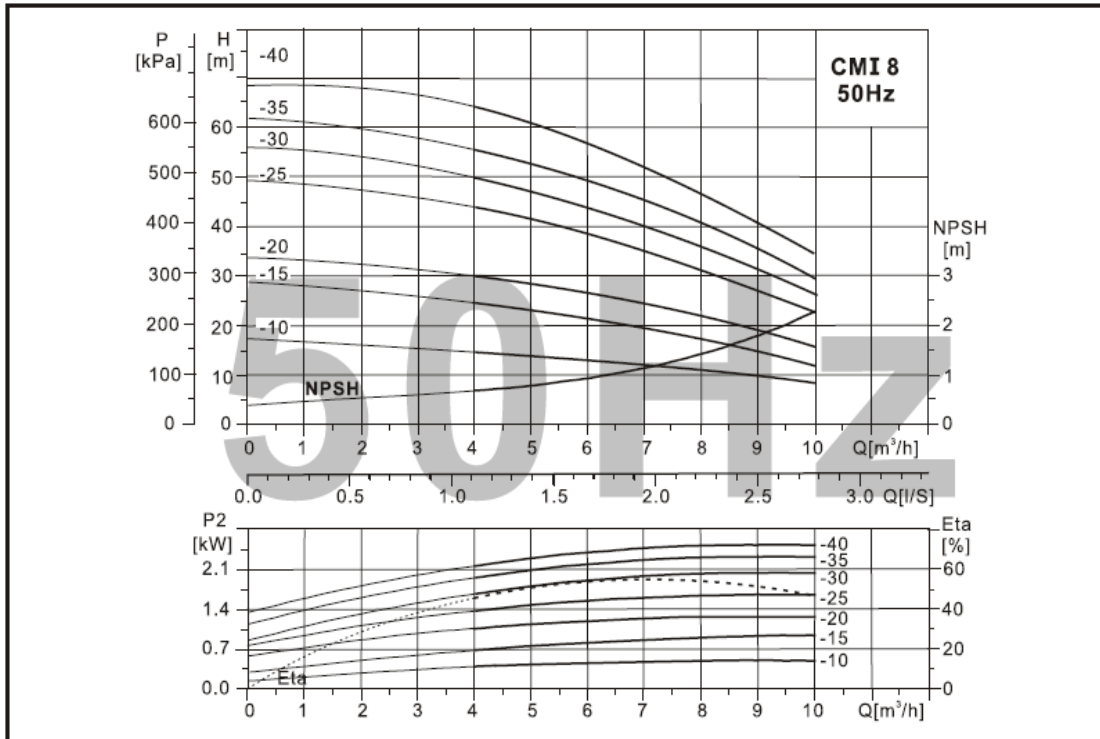

3.Product Appearance Dimensions And Technical Parameters

3.4.4 VFI8B Performance Curve

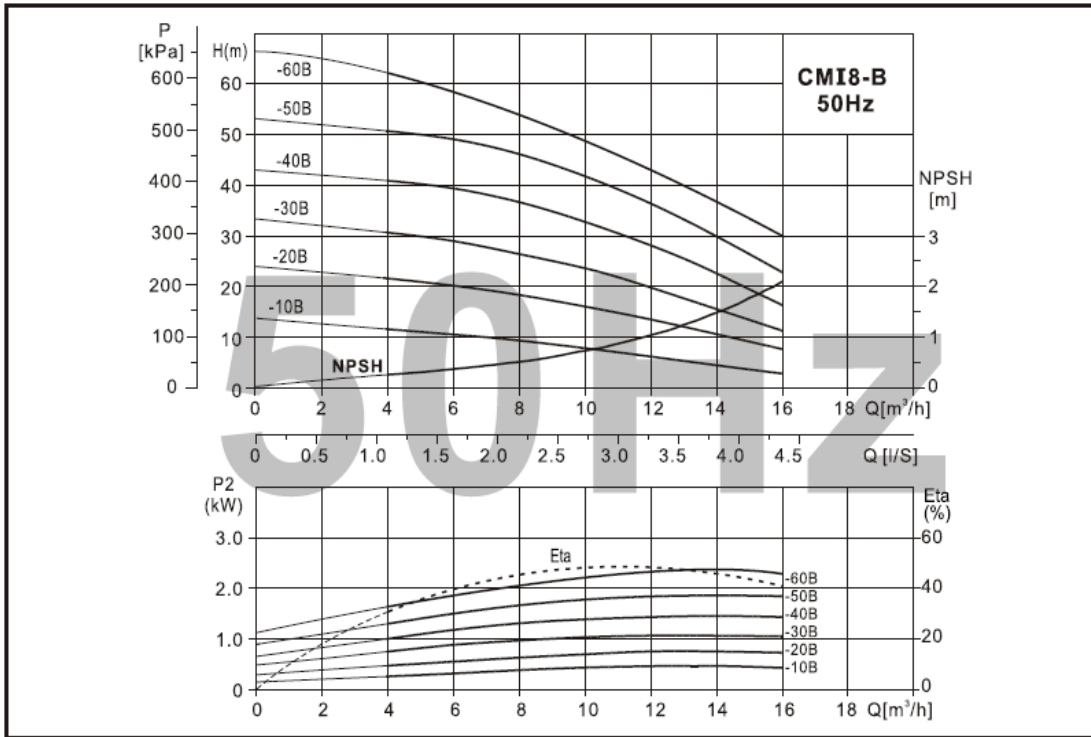

3.Product Appearance Dimensions And Technical Parameters

3.4.5 VFI12 Performance Curve

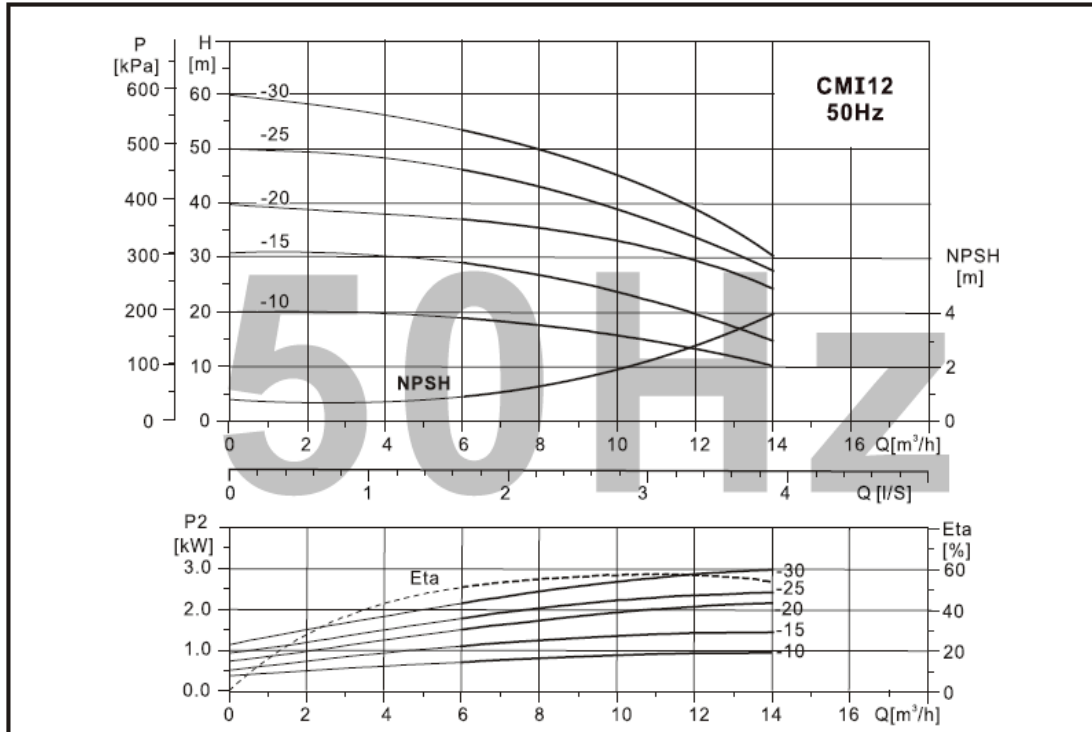

3.Product Appearance Dimensions And Technical Parameters

3.4.6 VFI12B Performance Curve

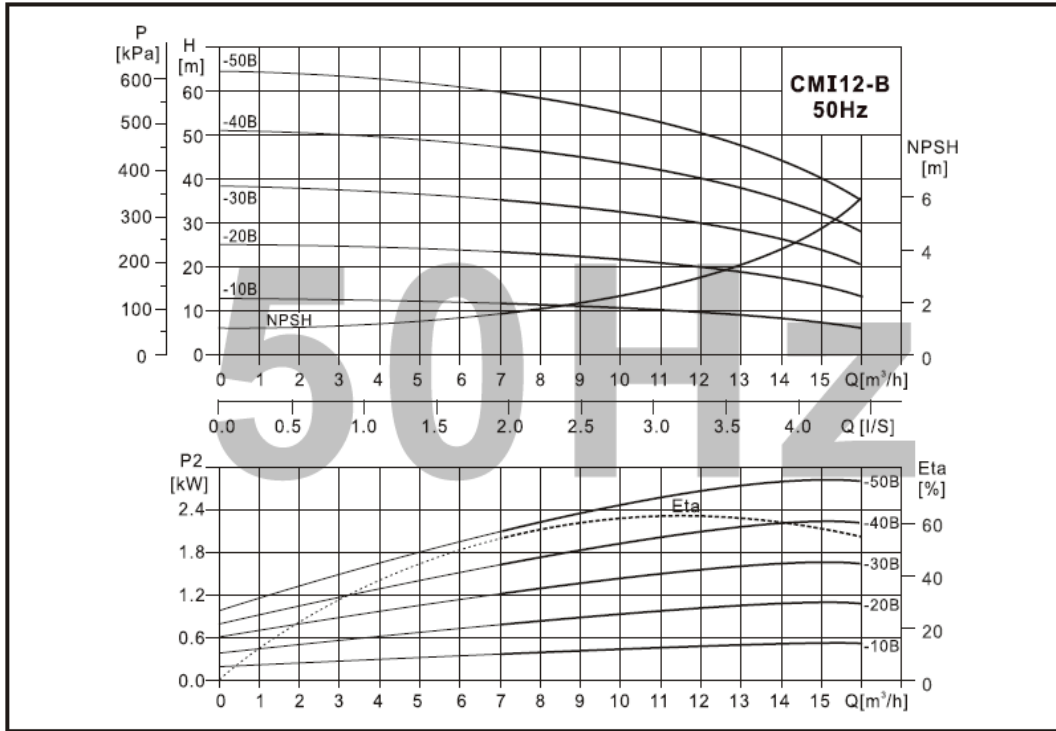

3.Product Appearance Dimensions And Technical Parameters

3.4.7 VFI16 Performance Curve

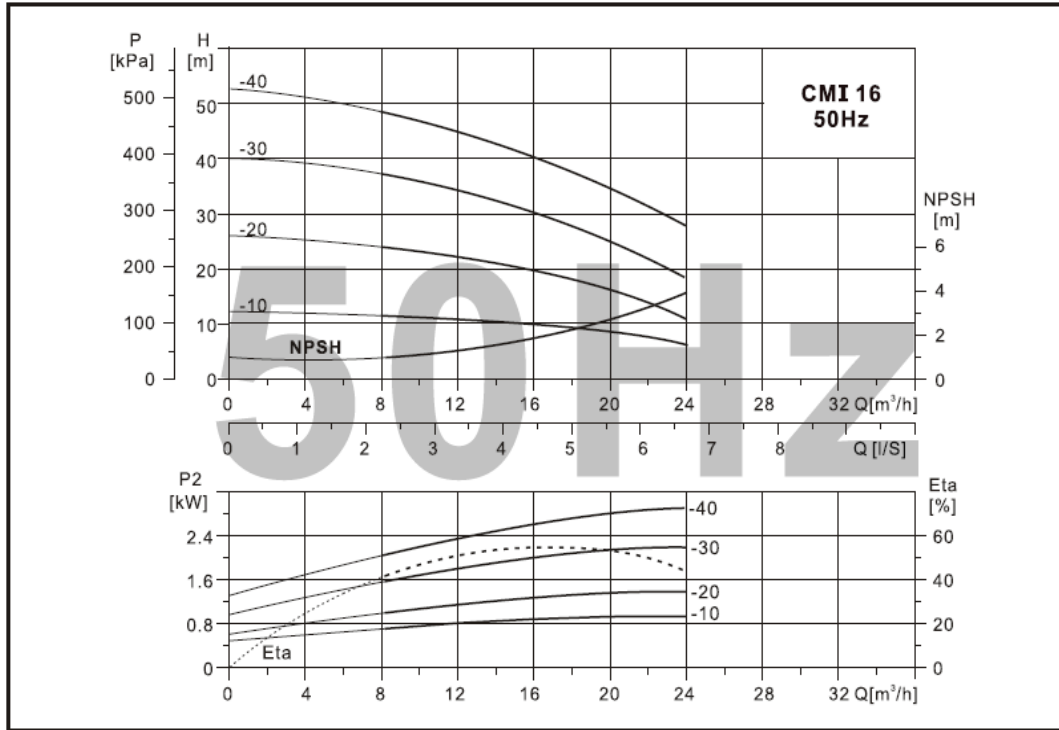

3.Product Appearance Dimensions And Technical Parameters

3.4.8 VFI20 Performance Curve

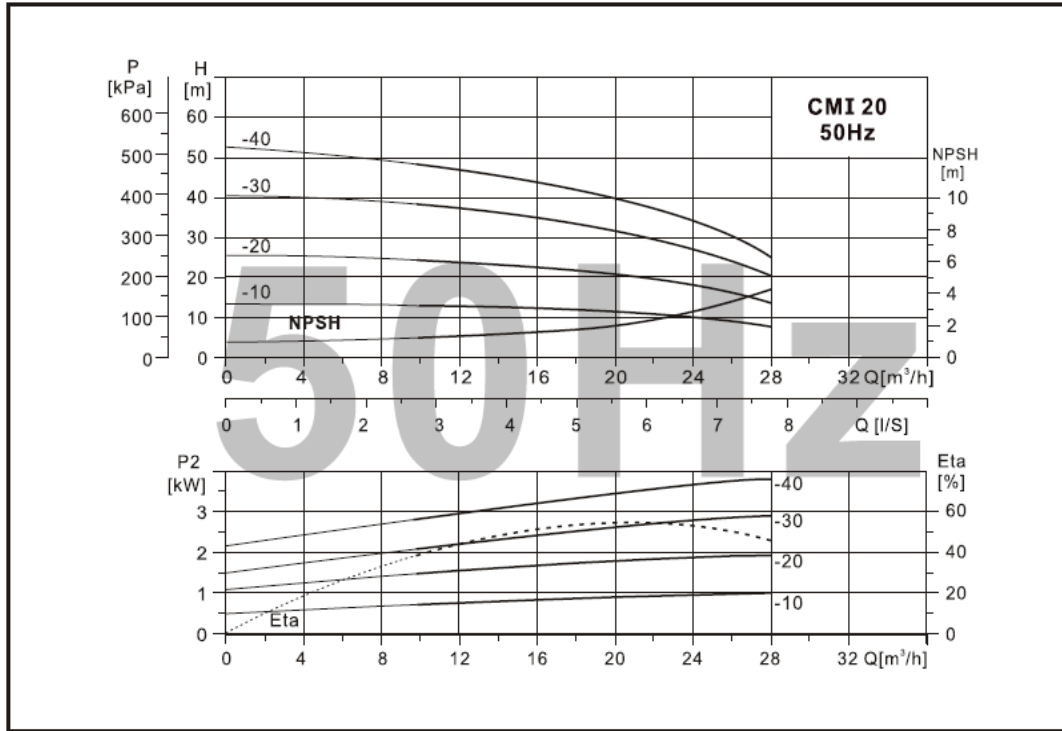

4.Installation and Operating Instruction

4.1 Structure diagram and installation instructions

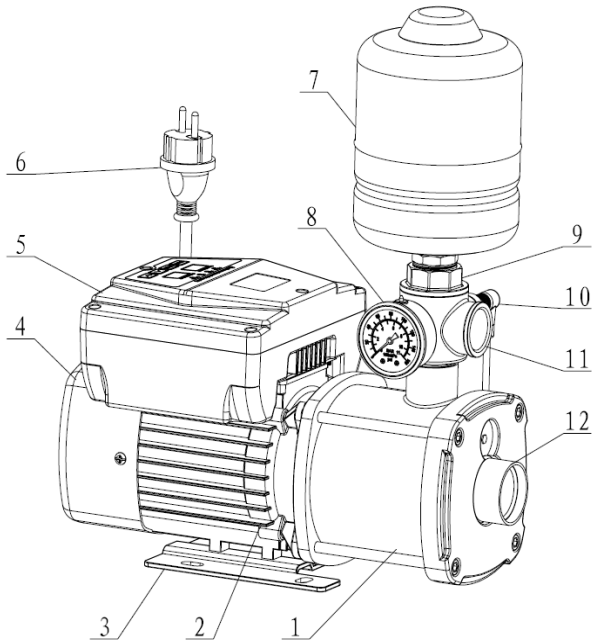

No.	Name	No.	Name
1	pump body components	7	pressure tank
2	inverter components	8	pressure gage
3	mounting plate	9	Five-way
4	fan cover	10	pressure sensor
5	inverter	11	outlet
6	power plug	12	inlet

Installation Requirements

- 1.Read the manual carefully before installation and using.
- 2.Check the pump and the power plug are damaged or not before installation .
- 3.Pump must be installed steady and firmly
- 4.Pump must be grounded reliable,and install an air switch on the incoming power cable side.
- 5.Check the input power and environment are conforming to the conditions of using.
- 6.Installing the strainer and check valve to avoid the sand into pump,or will shorten using life.
- 7.Use AC220V special purpose fixed socket which power is no less than 2times the rated power.

4.Installation and Operating Instruction

4.2 wiring diagram and instruction

The products have already finished the wiring according with the standard before leaving the factory.If the user want to change the wire or connect the wire for the special reasons,it must comply with the following requirements and notice:

Wiring Diagram	Requirements and Notice
<p>Wiring diagram</p> <p>To sensor 24V Psi 10bar 4~20mA</p> <p>To pump U V W 3~220V AC 50/60Hz M Ground</p> <p>To power PE N L1 1~220V AC 50/60Hz Line Line Ground</p>	1.Cut off the power before open panel.
	2.Don't connect the AC main circuit power supply and output terminals U、V.
	3.Connecting after the power supply is cut off.
	4.Verify the inverter rated voltage and the input supply voltage are consistent.
	5.The product can't take withstand test.
	6.Tightening torque of pressure line screws can't lower than 1.7N.m
	7.Make sure the ground terminal is connected before wiring the main circuit terminals.
8.Standards and specifications of changing cable must be longer than or equal to factory configuration.	
9.Connect input power after all parts installed well.	

4.3 Operation instruction

4.3.1 Checking before operation

- 1.Check the input power and surroundings is comply with the conditions of using.
- 2.Check the pressure sensor is connected with the system.

4.Installation and Operating Instruction

3.Check whether the product is firmly installed.





4.After connection is verified, make a empty running, if the pump is three-phase, to make sure that the motor running direction is correct, if motor running reversely, to exchange the terminal of UV , WV or UV, WU.

4.3.2 Operating Steps

1.Connect power , the current pressure area display “0.0”bar , and the setting pressure area display the set pressure vaule

2.Open the valve of outlet, and press  ” to start the pump .

3.Press“  ” to stop the pump in any case.

4.Press“  ” or “  ”, to check the working pressure ,if need to change the working pressure, press“  ”to increase the pressure or press “  ” to decrease the pressure .

5.Open the tap after setting pressure , the inverter will take frequency speed control on pump according to the water using status.Observing whether the pump is running normally,the pressure showed in the display whether is constant .If it does , the installation and debugging is finished,if not, take reference of the manual to remove the faults and debug it again.

4.Installation and Operating Instruction

4.3.3 Button and Function Instruction





Schematic Diagram	No	Name or Function	Instruction
-------------------	----	------------------	-------------

1	POWER	Current pressure display area	Display current pressure,unit is bar.
2	PUMP	Power indicator	It lights up when the power is on.
3	NET	Pump indicator	When the motor is in speed governing ,the indicator twinkles quickly.when in constant speed or lack of water,it twinkles slowly.when it automatic stoppes,the light is light.when the motor is stopped manually,the indicator light goes out.
4	SET	on-line indicator	When more than two pumps were working online, the host inverter indicactor were always on, and the slave indicator was flashing.
5	FAILURE	Pressure setting indicator	The indicator lights up when it's the setting pressure.
6		Water shortage indicator	The pipe is lack of water when indicator is light,the system is restart in the setting time when in the state,interval time is 8s,1min,10min、 30min、 1h、 2h...2h infinite loop.
7		Set pressure display area	Display current setting pressure,unit is bar.The factory default setting is 3bar
8	RUN	Increase button	press the button can decrease 0.1bar one time ,long time press can reduced rapidly.
9	STOP	Reduce button	press the button can increase 0.1bar one time ,long time press can increased rapidly.
10	▲	Stopping button	It can stop the pump manually,press this button to exit the water shortage state.
11	▼	Starting button	It can start the pump manually,press this button to exit the water shortage state .

4. Installation and Operation Instruction

4.3.4 Code and Instruction

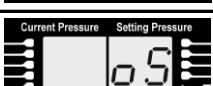
No.	Code name	Schematic diagram	Instruction
-----	-----------	-------------------	-------------

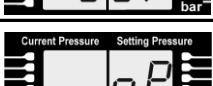
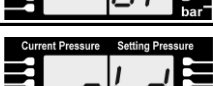
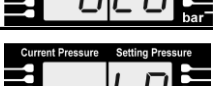
1	Over-Voltage protection	 The image shows a digital display with two sections. The left section is labeled 'Current Pressure' and the right section is labeled 'Setting Pressure'. Below the right section, the word 'bar' is visible. The display shows the code 'OU'.	when the voltage is higher than 270V shows this code,if the Voltage is lower than 260V, then recover to normal working situation
2	Under-Voltage protection	 The image shows a digital display with two sections. The left section is labeled 'Current Pressure' and the right section is labeled 'Setting Pressure'. Below the right section, the word 'bar' is visible. The display shows the code 'LU'.	when the voltage is lower than 100V shows this code ,if the Voltage is higher than 110V, then recover to normal working situation
3	Thermal protection	 The image shows a digital display with two sections. The left section is labeled 'Current Pressure' and the right section is labeled 'Setting Pressure'. Below the right section, the word 'bar' is visible. The display shows the code 'OC'.	When radiator temperature get to 80°C shows this code,if the temperature lower than 60°C,then recover to normal working situation
4	Sensor error	 The image shows a digital display with two sections. The left section is labeled 'Current Pressure' and the right section is labeled 'Setting Pressure'. Below the right section, the word 'bar' is visible. The display shows the code 'OS'.	When pressure sensor damaged or disconnect shows this code,recover to normal working situation after people check troubleshooting
5	Over pressure protection	 The image shows a digital display with two sections. The left section is labeled 'Current Pressure' and the right section is labeled 'Setting Pressure'. Below the right section, the word 'bar' is visible. The display shows the code 'OLP'.	When pipe pressure equal to 99% of pressure sensor pressure shows this code,if the the pressure lower than 96% of the pressure sensor pressure,then recover to normal working situation
6	Open phase protection	 The image shows a digital display with two sections. The left section is labeled 'Current Pressure' and the right section is labeled 'Setting Pressure'. Below the right section, the word 'bar' is visible. The display shows the code 'OP'.	When inputed three phase power open phase shows this code, recover to normal working situation after people check troubleshooting
7	Overload protection	 The image shows a digital display with two sections. The left section is labeled 'Current Pressure' and the right section is labeled 'Setting Pressure'. Below the right section, the word 'bar' is visible. The display shows the code 'OLd'.	When exceed the setcurrent or load power shows this code,recover to normal working situation after people check troubleshooting
8	Over-current or short circuit protection	 The image shows a digital display with two sections. The left section is labeled 'Current Pressure' and the right section is labeled 'Setting Pressure'. Below the right section, the word 'bar' is visible. The display shows the code 'OLP'.	When motor with short circuit or over-current problems shows this code,recover to normal working situation after people check troubleshooting

5. Maintenance

5.1 Product Maintenance

1.Maintenance needs to be professionals.

2.Without permission.clients cannot change the pump structure,regulation performance,etc.

Otherwise,our company will not be responsible for all the consequences.

3.In summer, ventilation measures must be provided,but the pump shall not be exposed to in sunlight or rain directly; Taking anti freezing measures in winter, but shall not use flammable materials.

4.If the pump long time no using, please cut off power, and open the bolt and keep pump dry.

